



Intelligent Vehicular Traffic Control System using Priority Longest Queue First Model

By Samuel S. Udoh, Francis B. Osang, Olutola O. Fagbolu & Michael E. Isang

University of Uyo

Abstract- Traffic congestion of vehicles at road intersections is a growing problem in many developing countries of the world, especially in large urban areas. This stems from a continuous increase in the human population, poor road networks and the proliferation of vehicles for transportation of humans and goods from one location to another towards the performance of civil, social and economic activities. These vehicles often meet at road intersections and desire the Right-of-Way (RoW) towards their destination. This situation always results in race competition, traffic jam and gridlock condition with its attendant effects on time, fuel wastages as well as accident and fire outbreak which often results to loss of lives and property. The conventional traffic light control system which employs a static time cycle for issuance of RoW to each lane at the intersection lacks human-like intelligence and traffic situational awareness.

Keywords: *intelligent system, priority longest queue, vehicular traffic, interval type-2 fuzzy logic.*

GJCST-D Classification: *1.2.0*



Strictly as per the compliance and regulations of:



Intelligent Vehicular Traffic Control System using Priority Longest Queue First Model

Samuel S. Udoh^α, Francis B. Osang^σ, Olutola O. Fagbolu^ρ & Michael E. Isang^ω

Abstract- Traffic congestion of vehicles at road intersections is a growing problem in many developing countries of the world, especially in large urban areas. This stems from a continuous increase in the human population, poor road networks and the proliferation of vehicles for transportation of humans and goods from one location to another towards the performance of civil, social and economic activities. These vehicles often meet at road intersections and desire the Right-of-Way (RoW) towards their destination. This situation always results in race competition, traffic jam and gridlock condition with its attendant effects on time, fuel wastages as well as accident and fire outbreak which often results to loss of lives and property. The conventional traffic light control system which employs a static time cycle for issuance of RoW to each lane at the intersection lacks human-like intelligence and traffic situational awareness. It is incapable of giving preferential treatment to signals from vehicles on critical-missions such as hospital ambulances carrying accident victims, fire service vehicles on critical rescue missions and security patrol vehicles on time-dependent operations. The conventional system does not also consider the queue density on each lane to determine the proportion of time allotment for RoW. This paper proposes a Priority Longest Queue First (PLQF) model for the assignment of RoW to vehicles at traffic intersections. The PLQF model was formulated using mathematical equations. Time allotment strategy was incorporated using interval type-2 fuzzy logic model. Inputs to the model were queue density, average waiting time and vehicle priority, while time allotted for RoW served as the output. The system was simulated using Java Development Toolkit (JDK) 8.0 and tested using traffic data collected from heavy traffic intersections at Uyo, Nigeria. Results showed superior performance of PLOF model over the conventional traffic system in terms of selection of lane and dynamic allotment of time for right-of-way.

Keywords: intelligent system, priority longest queue, vehicular traffic, interval type-2 fuzzy logic.

1. INTRODUCTION

Traffic congestion constitutes serious problems and a threat to road users with its attendant effects on grid lock, noise pollution, long waiting hours, wastage of fuel, time and money as well as accident which might result in loss of lives and property. In large

urban cities, intelligent traffic signal controller plays an important role in improving the efficiency of vehicles and traffic congestion thereby reducing travel time, noise pollution, carbon dioxide emission and amount of fuel used (Javed *et al.* 2015). Conventional traffic controller comprises a constant cycle of actions to be carried out based on received signals whose output are displayed in colours for instance red (stop), yellow (get-ready) and green (go) (Lee *et al.* 2002). Conventional traffic controller also grants equal allotment of time to each of the traffic routes (Maslekar *et al.* 2011). Equal time allotment to all routes is fair if all the routes have equal traffic density. This is seldom true in real-life traffic situations. At a given traffic intersection, there could be lanes with very high traffic density while others might have very low density. Marco (2014) opined that the strategies employed in conventional models' light control such as the use of constant cycle time for traffic control do not consider the traffic densities and analysis of situations at traffic intersections, thereby lacking adequate knowledge needed for dynamic response to complex and time-varying traffic scenarios. The static scheduling models grant cyclical permission and RoW to vehicles at intersections with no recourse to high traffic density routes or emergencies. This problem could be solved by incorporation of the Priority Longest Queue First (PLQF) model at the traffic controller. The PLQF model evaluates the density of each lane as well as the emergency signal to select the lane for traffic flow. Incorporation of an intelligent tool such as interval type-2 fuzzy logic for traffic pattern evaluation facilitates dynamic time allotment based on queue parameters. Fuzzy Logic (FL) developed in (Zadeh 1975) as a mathematical tool for dealing with imprecision and uncertainty has been successfully applied in (Obot 2007; Inyang 2014; Udoh 2016, Udoh *et al.* 2017, Udoh *et al.* 2019) for pattern classification and derivation of definite conclusions from vague and ambiguous information. In this work, PLQF was formulated for the selection of lanes for RoW. The data (queue density, average waiting time, number of priority vehicles) of the selected lane served as input to interval type-2 fuzzy logic module for pattern classification to guide traffic time allocation. In the remaining parts of this paper, reviews of some related works on vehicular control models are presented in section 2. The concept of PLQF model for traffic control is presented in section 3. Sections 4 and 5 contain results of simulations of the

Author α ω: Department of Computer Science, University of Uyo, Uyo, Nigeria. e-mails: samueludoh@uniuyo.edu.ng, mikeisang@yahoo.com

Author σ: National Open University of Nigeria, Abuja, Nigeria. e-mail: fosang@noun.edu.ng

Author ρ: Department of Mathematics and Statistics, Fourah Bay College, University of Sierra Leone, Freetown, Sierra Leone. e-mail: fagbolu.olutola@usl.edu.sl

PLQF model and the conclusion of the work respectively.

II. RELATED WORKS

Tubaishat et al. (2007), investigated vehicular traffic control system using wireless sensors. The sensors were installed at designated locations at the traffic intersection. The number of vehicles between two sensors at each lane of the intersection formed the queue density for that lane. Results showed that the distance between two sensors on the same lane had no significant effect on traffic volume. The average waiting time of vehicles was not compared with other traffic control models to ascertain the performance of the proposed system. The work in (Zhou et al. 2010) developed an adaptive traffic light control algorithm that adjusted both the sequence and length of the traffic light in accordance with the real-time traffic situation. The algorithm selected the sequence of phases among a set of conflict-free situations according to multiple criteria: traffic volume, priority vehicles, waiting time, starvation degree and queue lengths. Results showed that traffic throughput was maximized and average waiting time was minimized. However, the algorithm was based on the assumption that all vehicles were of the same type and run at the same speed. This is rarely true in a typical traffic scenario. Osigwe, et al. (2011) presented a hybrid methodology obtained from the crossing of the structured system analysis and fuzzy logic-based design methodologies. An analysis of current traffic systems in Nigeria was carried out which necessitated the design of an intelligent traffic control system. Java software was used for the simulation of the system. The fuzzy logic provided better performance in terms of total waiting time and total moving time. Emergency and high-priority vehicles were not captured in the design. The work in (Prajakta et al. 2011) surveyed multi-agent techniques for traffic congestion management. Limitations of existing non-multi-agent-based congestion management techniques were found to include lack of robustness, coordination and adaptivity which predominantly stem from factors such as lack of communication between elements of the traffic control system. This limits the capability of existing systems to act autonomously and respond to fast-changing traffic conditions. In (Harpel et al. 2012), an intelligent traffic light based on Radio Frequency Identification (RFID) was proposed. The work gave priority to emergency vehicles but did not consider high-density lanes. Lack of consideration of high-density lanes led to increase in traffic jams and average waiting time at traffic intersections. The work in (Escalera et al. 2013) employed a fuzzy type-1 light controller to control the phase-splits of the traffic light at road intersections. The system provided better performance in terms of total waiting time but lacked the capacity for adequate

handling of uncertainties in traffic input parameters. In (Rajeswaran and Rajasekaran 2013), Cellular Automata (CA) model was explored to model traffic flow. The traffic intersection was mathematically idealized with vehicles and time viewed as discrete quantities. The CA model was applied to a single-lane highway with a ring topology and a two-lane traffic flow intersection. Performance metrics were generally obtained through computer simulation of the evolution of the cellular automaton over time. Anuran et al. (2014) proposed an Intelligent Traffic Control Systems (ITCS) using Radio Frequency Identification (RFID). The ITCS comprised a set of two RFID readers, separated by some distance, in each direction of a road crossing and a Central Computer System (CCS) to control them. As a vehicle passed by a reader, it tracked the vehicle through the RFID tag attached to the vehicle and retrieved its electronic product code data which primarily consisted of a Vehicular Identification Number (VIN). Through a table look-up procedure, the VIN was matched against individual vehicle records and details such as type, weight, length, registration, pollution control status and the owner's identification were retrieved. The data was sent to the CCS for computation. The CCS employed a central database processing system for computing vehicular data and a decision-making section for controlling the traffic signals. The system was implemented in real-time. It helped in tracking stolen vehicles as well as vehicles booked for violating traffic rules. Peculiarities for high-priority vehicles were envisaged for preferential allotment of right-of-way. An interrupt handler was suggested to suspend normal automation in case of emergency. Human-like intelligent tools were not incorporated to handle dynamic time allotment on the lanes. Pati (2016) proposed an intelligent traffic control system based on K-mean algorithm. The system considered high-priority vehicles such as ambulance and fire service vehicles. Tools were not incorporated for dynamic allotment of time for RoW to the traffic lane. Analysis of traffic scenario was carried out using a single lane hence could not capture the ideal situation at multi-lanes traffic intersection. In (Uthara and Athira, 2018), image processing technique was employed in the design of density-based traffic control system. A webcam was used in each lane of the traffic light in order to take pictures of the roads where traffic was bound to occur. Counting of vehicles was carried out using image processing tools in Mat Lab environment. Different timings were allocated for RoW on the lanes based on the counts. The design of a smart traffic controller for vehicles and pedestrians was implemented in Adnan et al. (2018) using fuzzy logic tools in a Mat Lab environment. The system allotted different time signals for RoW at different lanes based on queue density. Considerations were not given to high-priority vehicles like ambulance, fire service, police patrol teams, and so on. This hindered the human-like

preferential considerations at traffic intersections. Zhuzhou *et al.* (2019), used Simulation of Urban Mobility (SUMO), an open-source, microscopic and multi-modal traffic simulation software to extract vehicle density at the traffic intersection in Vehicular Adhoc Network (VANET) environment. The Vehicle-to-Vehicle (V2V) and Vehicle-to-Infrastructure (V2I) interaction technologies created better conditions for collecting the whole time-space and refined traffic data. A real-time traffic density extraction method was proposed to cater for lane

density and road network density. The extracted traffic densities could be employed for efficient traffic management at traffic intersections.

III. METHODOLOGY

The conceptual architecture of the Intelligent Vehicular Traffic Control System (IVTCS) is presented in figure 1. The architecture comprises the component of the IVTCS and the relationship among them.

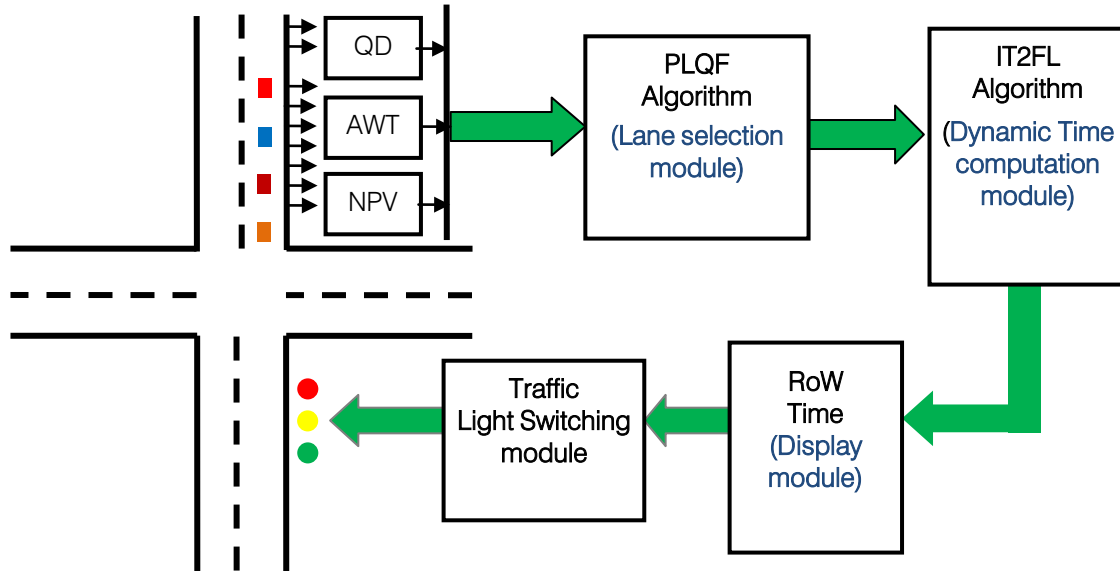

Figure 1: Conceptual Architecture of Intelligent Vehicular Traffic System

The proposed system framework is shown in Figure 1 consists of the following components:

1. Inputs: These are parameters used in selecting the optimal lane as well as computing the traffic time. These traffic parameters are Queue Density (QD), Average Waiting Time (AWT) and Number of Priority Vehicles (NPV).
2. Priority Longest Queue First (PLQF) model is proposed in this work to determine the optimal lane at any given instance.

3. Interval Type-2 Fuzzy Logic (IT2FL) algorithm is used to evaluate the traffic time based on the input parameters (called crisp input).
4. Right-of-Way (RoW) Time value – This is the output of the fuzzy logic algorithm (the crisp output), the value is used in allotting time for right-of-way for the selected lane,
5. Traffic Light Switching module – This is the interface that switches the traffic lights based on the lane selected by PLQF and time allotted by IT2FL algorithm.

a) Formulation of Priority Longest Queue First (PLOF) Model

The formulation of the PLOF model using mathematical equations is presented as follows:

Let the traffic function λ at the moment m_t at a traffic intersection with lanes r be modeled by equations 1 to 22

$$\lambda = m_t(\bar{x}_r, p_r, q_r) \quad | \quad (t, r \in \mathbb{Z}^+) \tag{1}$$

$$\bar{x}_r = \frac{\sum_{i=1}^n(x_{r,i})}{n} \tag{2}$$

$$\varphi_r = \omega(\alpha(p_r)) \tag{3}$$

$$f(\varphi_r(p_r; [a_1, a_2], b, [c_1, c_2])) = \begin{cases} 0, & p_r \leq [a_1, a_2] \\ \frac{p_r - [a_1, a_2]}{b - [a_1, a_2]}, & [a_1, a_2] \leq p_r \leq b \\ \frac{[c_1, c_2] - p_r}{[c_1, c_2] - b}, & b \leq p_r \leq [c_1, c_2] \\ 0, & [c_1, c_2] \leq p_r \end{cases} \quad (4)$$

$$f(\varphi_r(q_r; [a_1, a_2], b, [c_1, c_2])) = \begin{cases} 0, & q_r \leq [a_1, a_2] \\ \frac{q_r - [a_1, a_2]}{b - [a_1, a_2]}, & [a_1, a_2] \leq q_r \leq b \\ \frac{[c_1, c_2] - q_r}{[c_1, c_2] - b}, & b \leq q_r \leq [c_1, c_2] \\ 0, & [c_1, c_2] \leq q_r \end{cases} \quad (5)$$

$$f(\varphi_r(\bar{x}_r; [a_1, a_2], b, [c_1, c_2])) = \begin{cases} 0, & \bar{x}_r \leq [a_1, a_2] \\ \frac{\bar{x}_r - [a_1, a_2]}{b - [a_1, a_2]}, & [a_1, a_2] \leq \bar{x}_r \leq b \\ \frac{[c_1, c_2] - \bar{x}_r}{[c_1, c_2] - b}, & b \leq \bar{x}_r \leq [c_1, c_2] \\ 0, & [c_1, c_2] \leq \bar{x}_r \end{cases} \quad (6)$$

$$\tau_r = f(\varphi_r(p_r, q_r, \bar{x}_r)) \quad (7)$$

where

\bar{x}_r is the average waiting time of vehicles starting at point (s_1) and stopping at point (s_2) at r^{th} lane of the intersection.

$x_{r,i}$ is the arrival time of i^{th} vehicle at r^{th} lane of the intersection.

p_r is the number of priority vehicles at r^{th} lane of the intersection

q_r is the queue length of vehicles at r^{th} lane of the intersection, obtained by counting the number of vehicles in the section within points (s_1, s_2)

\mathbb{Z}^+ is the set of positive integers

α is the priority comparison function

ω is the priority ordering function

φ_r is the lane priority selection function.

$f(\varphi_r(p_r))$ is the interval type 2 fuzzy function for lane priority

$f(\varphi_r(q_r))$ is the interval type 2 fuzzy function for queue length of the selected lane

$f(\varphi_r(\bar{x}_r))$ is the interval type 2 fuzzy function for mean arrival time of the selected lane

a is the left leg of the triangular membership function,

b is the center of the membership function (it is constant for both upper and lower membership functions)

c is the right leg of the membership function, $[a_1, a_2]$ is the left leg of the lower and upper membership function, and $[c_1, c_2]$ is the right leg of the lower and upper membership functions.

τ_r is the dynamic time allotment function for right-of-way to r^{th} lane of the intersection

b) *The Karnik Mendel Algorithm*

The Karnik Mendel (KM) Algorithm is employed for interval type-2 fuzzy logic reduction. The algorithm seeks to find switch points (L, R), leftmost point (y_l) and the rightmost point (y_r) as expressed in equations 8 and 9 respectively

$$\underline{y}^L \leq y_l \leq \underline{y}^{L+1} \tag{8}$$

$$\bar{y}^R \leq y_r \leq \bar{y}^{R+1} \tag{9}$$

KM Algorithm for Computing y_l

Step 1: sort \underline{y}^n ($n = 1, 2, \dots, N$) in increasing order and call the sorted \underline{y}^n by the same, but now $\underline{y}^1 \leq \underline{y}^2 \leq \dots \leq \underline{y}^N$. Match the weights $F^n(X')$ with their respective \underline{y}^n and renumber them so that their index corresponds to the re-numbered \underline{y}^n .

Step 2: Initialize f^n by setting

$$f^n = \frac{f^n + \bar{f}^n}{2} \quad n = 1, 2, \dots, N \tag{10}$$

And then compute

$$y = \frac{\sum_{n=1}^R \underline{y}^n f^n}{\sum_{n=1}^R f^n} \tag{11}$$

Step 3: Find the switch point k ($1 \leq k \leq N - 1$) such that

$$\underline{y}^k \leq y \leq \underline{y}^{k+1} \tag{12}$$

Step 4: Set $f^n = \begin{cases} \bar{f}^n, & n \leq k \\ f^n, & n > k \end{cases} \tag{13}$

And compute

$$y' = \frac{\sum_{n=1}^N \underline{y}^n f^n}{\sum_{n=1}^N f^n} \tag{14}$$

Step 5: Check if $y' = y$. If yes, stop and set $y_l = y$ and $L = k$. if no, go to Step 6.

Step 6: Set $y = y'$ and go to Step 3

KM Algorithm for Computing y_r

Step 1: Sort \bar{y}^n ($n = 1, 2, \dots, N$) in increasing order and call the sorted \bar{y}^n by the same, but now $\bar{y}^1 \leq \bar{y}^2 \leq \dots \leq \bar{y}^N$. Match the weights $F^n(X')$ with their respective \bar{y}^n and renumber them so that their index corresponds to the re-numbered \bar{y}^n .

Step 2: Initialize f^n by setting

$$f^n = \frac{f^n + \bar{f}^n}{2} \quad n = 1, 2, \dots, N \tag{15}$$

And then compute

$$y = \frac{\sum_{n=1}^N \bar{y}^n f^n}{\sum_{n=1}^N f^n} \tag{16}$$

Step 3: Find the switch point k ($1 \leq k \leq N - 1$) such that $\bar{y}^k \leq y \leq \bar{y}^{k+1}$

Step 4: Set $f^n = \begin{cases} f^n, & n \leq k \\ \bar{f}^n, & n > k \end{cases}$

And compute

$$y' = \frac{\sum_{n=1}^N \bar{y}^n f^n}{\sum_{n=1}^N f^n} \tag{17}$$

Step 5: Check if $y' = y$. If yes, stop and set $y_r = y$ and $R = k$. if no, go to Step 6.

Step 6: Set $y = y'$ and go to Step 3

The algorithm to find the leftmost and the rightmost points are given in Equations 18 and 19

$$y_l = \min_{L \in [1, N-1]} \frac{\sum_{n=1}^L f^n \underline{y}^n + \sum_{n=L+1}^N \underline{y}^n f^n}{\sum_{n=1}^L f^n + \sum_{n=L+1}^N f^n} \tag{18}$$

$$y_r = \max_{R \in [1, N-1]} \frac{\sum_{n=1}^R \underline{y}^n f^n + \sum_{n=R+1}^N \bar{y}^n f^n}{\sum_{n=1}^R f^n + \sum_{n=R+1}^N f^n} \tag{19}$$

where: \bar{f}^n is Upper Firing Strength, f^n is Lower Firing Strength, \bar{y}^n is Upper Consequent Set, \underline{y}^n is Lower Consequent Set, N is Number of Firing Rules

c) *Inference Engine*

A Mamdani type inference mechanism is used to evaluate the rules in the rule-base against the fuzzy set. This is done using Equations (20) – (22)

$$F^i(x') = [f^i(x'), \bar{f}^i(x')] \equiv [f^i, \bar{f}^i]E \tag{20}$$

$$\underline{f}^i(x') = \underline{\mu}_{F_1^i}(x') * \dots * \underline{\mu}_{F_i^i}(x_p') \tag{21}$$

$$\bar{f}^i(x') = \bar{\mu}_{F_1^i}(x') * \dots * \bar{\mu}_{F_i^i}(x_p') \tag{22}$$

where:

$\underline{f}^i(x')$ is the antecedent set of lower membership function

$\bar{f}^i(x')$ is the antecedent set of upper membership function

$\underline{\mu}_{F_1^i}(x')$ is the fuzzy set of lower membership function

$\bar{\mu}_{F_1^i}(x_p')$ is the fuzzy set of upper membership function

i is the rule number

d) *Algorithm implementing PLQF*

The pseudo code implementing the PLQF algorithm is given as follows:

1. PLQF (m_t, \bar{x}_r, p_r, q_r)
2. BEGIN
3. // traffic parameters
4. m_t is the moment of traffic capture at intersection; $t \in \mathbb{Z}^+ // \mathbb{Z}^+$ is a set of positive integers
5. r is number of lanes at traffic intersection; $r \in \mathbb{Z}^+$
6. \bar{x}_r is the average waiting time of vehicles at specified section of r^{th} lane
7. p_r is the number of priority vehicles at r^{th} lane of the intersection

8. q_r is the queue length of vehicles at r^{th} lane of the intersection
9. sis traffic controlsignal // (s = 0: means continue; s = 1: means stop control)
10. Initialize; s = 0
11. DO WHILE s = 0
12. At moment m_t the traffic function (λ) at the intersection depends on: (\bar{x}_r, p_r, q_r)
13. Call the priority comparison function (α) to compare the priorities of vehicles p_r .
14. Call the priority ordering function (ω) to sort the lanes based on ascending order of p_r .
15. For r = 1 to n
16. Select the lane for issuance of the right-of-way based on the order obtained in step 14
17. In each selected lane (ϕ_r), implement interval type-2 fuzzy logic on: (\bar{x}_r, p_r, q_r)
18. Apply KM Algorithm in Equations (8) - (19) for Type Reduction and Equations (20)– (22) for inferencing in Step 17
19. Determine the time (τ_r)for right-of-way based on the output in step 17
20. Next r
21. IF stop traffic signal is received Then
22. Go To step 28
23. Else
24. s = 0
25. $m_t = m_{t+1}$
26. Go To step 11
27. END IF
28. END DO
29. END //end Algorithm PLQF

IV. RESULTS AND DISCUSSION

The PLQF algorithm was programmed using Java Development Toolkit (JDK) 8.0. In order to assess the practical function of the program, the system was simulatedusing1020 traffic data scenarios collected from three (3) traffic intersection sat Uyo, Akwa Ibom State, Nigeria. Data attributes collected were: Average Waiting Time (AWT) of vehicles on each lane, Queue Density (QD) and Number of Priority Vehicles (NPV) on each lane. The PLQF program employed data captured at traffic intersection as input to the system. The data was processed to facilitate the selection of lanes for RoW. Time for RoW in each lane was computed using interval type-2 fuzzy strategy. The traffic simulation interface is presented in Figure 2. It shows, RoW given to the East lane. The traffic patterns for 20 traffic instances extracted from 1020scenarios observed at traffic inter sections are depicted in Figure 3. Time for RoW was found to covary strongly with QD and AWT. There by showing the ability of the PLQF system to allot time to traffic lane with human-like intelligence.

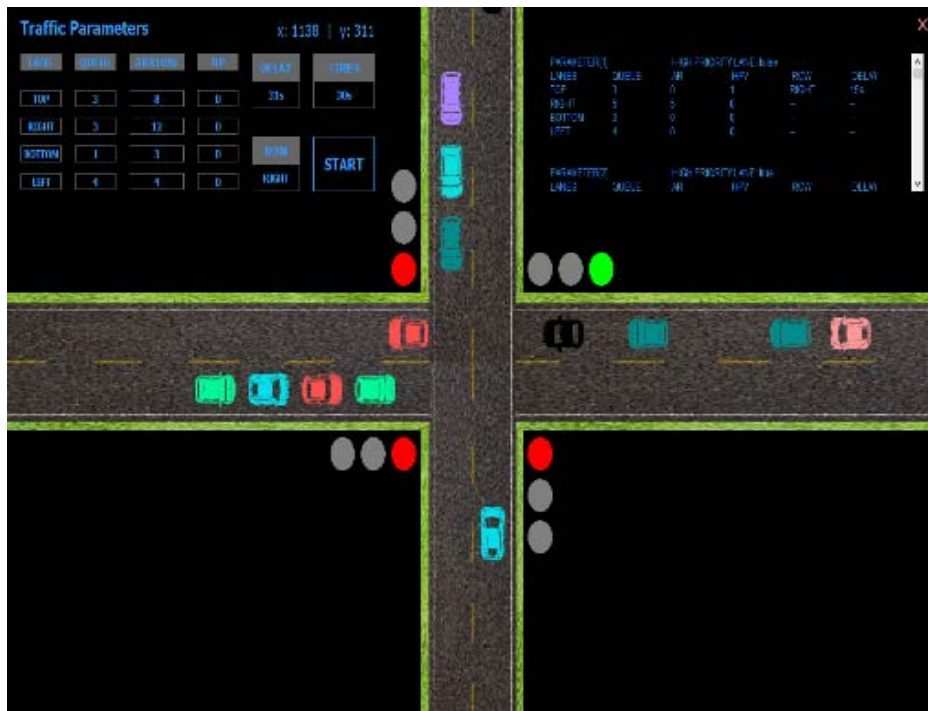

Figure 2: Right-of-Way given to East Lane

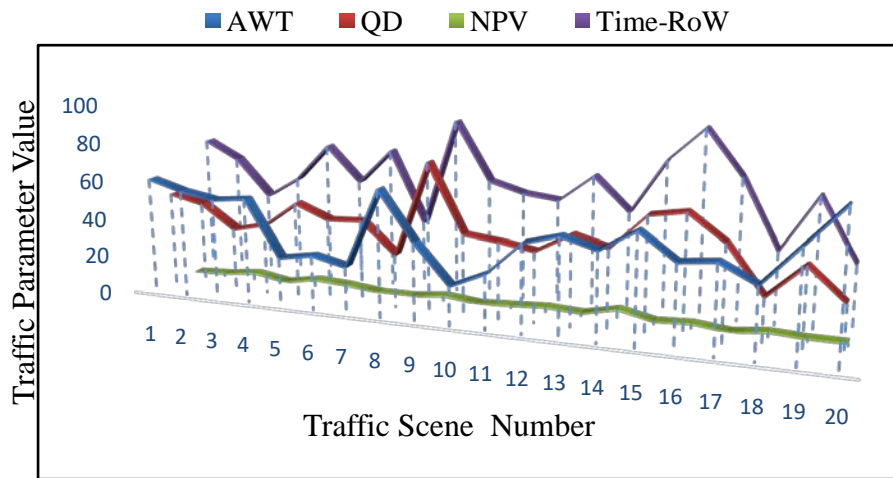

Figure 3: Traffic Pattern at Intersection

An instance of traffic parameters and the RoW decisions obtained from the PLQF system is depicted in Table 1.

Table 1: Traffic parameter instance and decision

Traffic Parameters				PLQF Traffic decisions		
Lane	AWT	QD	NPV	RoW Priority	Lane	Time
North	60	47	0	1	East	46
West	55	44	1	2	West	61
East	52	33	3	3	North	70
South	54	35	0	4	South	53

The traffic parameters segment captures the average waiting time, queue density and number of priority vehicles on each lane. For instance, in the North lane, the system captured 47 vehicles with an average waiting time of 60 seconds, the lane had no priority vehicle as at the time of capturing. The West lane had 1 priority vehicle in a total queue of 44 vehicles with an average waiting time of 55 seconds. The East lane had 3 priority vehicles in a total queue of 33 vehicles with an average waiting time of 52 seconds. The 35 vehicles in the South lane had an average waiting time of 54 seconds with no priority vehicle. The PLQF-based system employed the captured data to assign the RoW to the traffic lane as shown in the traffic decisions

segment. Although the North lane had more vehicles in the queue with the highest average waiting time, followed by the West and the South lanes, the East lane had the RoW first because it had 3 priority vehicles in the queue. The fuzzy component of the system utilized the QD, AWT and NPV to allocate the time of 46 seconds for the RoW. Similarly, 61, 70 and 53 seconds were allocated as the time of RoW to West, North and South lanes respectively. A comparison of the PLQF model with the conventional pre-timed control system results at the traffic intersection is depicted in Table 2. The correlation coefficient and standard error of the PLQF model are shown in Table 3.

Table 2: Comparison of Traffic parameter instance and decision

Traffic Parameters				Pre-timed Traffic model decision			PLQF Traffic decision (Current study)		
Lane	AWT	QD	NPV	RoW Priority	Lane	Time	RoW Priority	Lane	Time
North	60	47	0	1	North	45	1	East	46
West	55	44	1	2	West	45	2	West	61
East	52	33	3	3	East	45	3	North	70
South	54	35	0	4	South	45	4	South	53

Table 3: PLQF parameters correlation and standard errors

Traffic Parameters	Correlation	Standard Error
Time_RoW versus QD	0.94	0.004
Time_RoW versus AWT	0.83	0.008
Time_RoW versus NPV	0.71	0.09
Average	0.826	0.034

As shown in Table 2. The pre-timed model is static in its operation. It follows the First-Come-First-Serve (FCFS) strategy and assigns a static time of 45 seconds for RoW to any lane, irrespective of traffic patterns, whereas the PLQF model decision for RoW

selection and time allotment is dynamic based on QD, AWT and NPV. The interpolation of QD, AWT and NPV with time for RoW in the PLQF model is depicted in Figures 4 to 6.

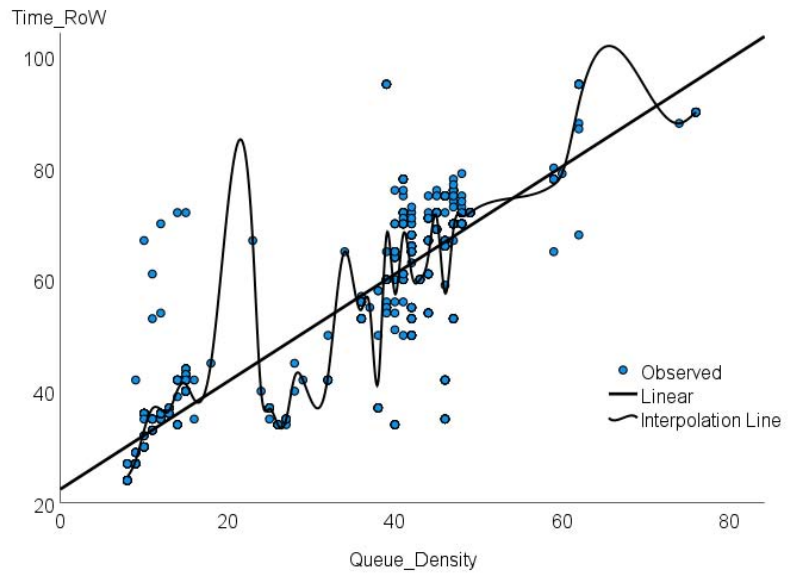

Figure 4: Interpolation of Queue Density with Time for RoW

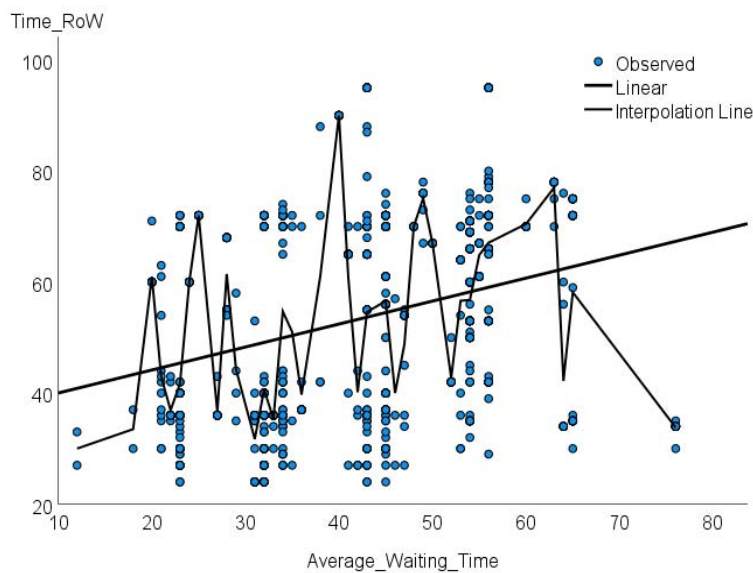

Figure 5: Interpolation of Average Waiting Time with Time for RoW

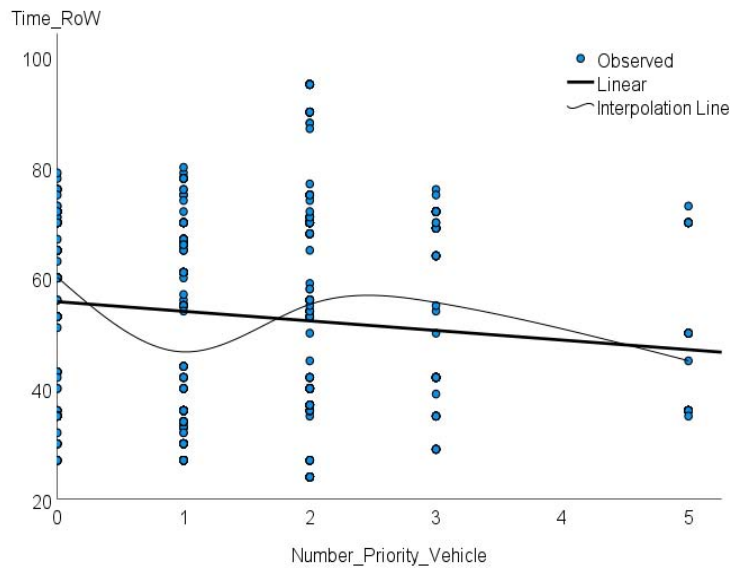

Figure 6: Interpolation of Number of Priority Vehicles with Time for RoW

Computation of correlation coefficient on 1020 instances of traffic patterns at the intersection resulted in correlation values of 0.94, 0.83 and 0.71 between QD versus time for RoW, AWT versus time for RoW and NPV versus time for RoW respectively. Computation of standard error resulted in the values of 0.004, 0.008 and 0.09 between QD versus time for RoW, AWT versus time for RoW and NPV versus time for RoW respectively. Mean correlation and standard error of 0.826 and 0.034 respectively were observed for traffic parameters (QD, AWT and NPV). The highest correlation value of 0.94 and lowest standard error value of 0.004 were observed between QD and time for RoW. This implies that the PLQF algorithm has human-like intelligence for dynamic allotment of time for right-of-way based on traffic patterns that covary very strongly with queue density at the intersection.

V. CONCLUSION AND RECOMMENDATION

This paper has developed a PLQF algorithm for the control of vehicular traffic at road intersections. Time allotment strategy was incorporated using interval type-2 fuzzy logic model. Inputs to the model were average waiting time, queue density and number of priority vehicles, while time allotted for RoW served as the output. PLQF model was formulated using mathematical equations. The system was simulated using Java Development Toolkit (JDK) 8.0 and tested using traffic data collected from heavy traffic intersections at Uyo, Nigeria. Results showed superior performance of PLQF model over the conventional traffic system in terms of selection of lane and dynamic allotment of time for right-of-way. The results from PLQF model invariably alleviate the sufferings of road users, maintain intelligent fairness, reduce traffic congestion, offer rational solutions to diverse situations on specific traffic lanes depending on

queue density, average waiting time, emergencies and needs. Future work would critically investigate and compare the average turn-around-time of the PLQF model with other intelligent vehicular traffic models for traffic management at intersections.

REFERENCES RÉFÉRENCES REFERENCIAS

1. Adnan, Pavan, K, D and Abdelwahed, M. (2018). Smart Traffic Controller using Fuzzy Logic. *International Journal of Advanced Research in Computer and Communication Engineering*. Pp 25-32.
2. Anuran C., Saumya B., Anirudhha C. (2014). Intelligent Traffic Control System using RFID. *Journal of IEEE DOI: 10.1109/MPOT.2009.932094* · Source: IEEE Xplore.
3. Escalera, A., J. M. Armingol and M. Mata. (2013). Traffic sign recognition and analysis for intelligent vehicles. *Image and Vision Computing* 21(3), Pp 247-258.
4. Harpel Singh, Krishan Kumar and Harbans Kaur (2012). Intelligent Traffic Lights Based on RFID. *International Journal of Computing and Business Research*. Pp, 1-9
5. Inyang, U. G. and Akinyokun, O. C., (2014). A Hybrid Knowledge Discovery System for Oil Spillage Risks Pattern Classification. *Journal of Artificial Intelligence*. 3(4), pp73-86.
6. Javed, Alam and Pandey, Manoj Kumar (2015). Design and Analysis of a Two Stage Traffic Light System Using Fuzzy Logic. *Journal of Information Technology*.
7. Lee, G. D. & Kim, S. W., (2002). A longitudinal control system for a platoon of vehicles using a fuzzy-sliding mode algorithm. *Mechatronics*, 12(1), Pp 97-118.

8. Mamdani, E. H. (1975). An Experiment in Linguistic Synthesis with a Fuzzy Logic Controller. *International Journal of Man-Machine Studies*, vol. 7, pp. 1-12.
9. Marco Wiering, Jelle Van Veenen, Jilles Vrecken and Ame Koopman (2014). Intelligent.
10. Traffic Light Control. *Institute of Information and Computing Sciences, Utrecht University Technical Report*, UU-CS-2004-029, Netherlands.
11. Maslekar, M, M. and Boussedjra, J. Mouzna, (2011). VANET Based Adaptive Traffic Signal Control. *Vehicular Technology Conference (VTC Spring)*.
12. Mendel, J. M. (2001). On the importance of Interval Sets in Type-2 Fuzzy Logic Systems.
13. Mendel, J. M. and Q. Liang (2000). Pictorial Comparisons of Type-1 and Type-2 Fuzzy Logic Systems. *IASTED International Conference on Intelligent Systems and Control, Santa Barbara, CA*.
14. Obot, O. U., (2007). Neuro Fuzzy Expert System For the Diagnosis and Therapy of Cardiovascular Diseases. Ph. D Thesis Dissertation, Department of Computer Science, Federal University of Technology, Akure. pp 56-95.
15. Osigwe, C., Oladipo F., Onibere, E. (2011). Design and simulation of Intelligent Traffic Control System. *International Journal of Advances in Engineering & Technology*.
16. Pati Vidya (2016) Intelligent Traffic Control System. *International Journal of Engineering Technology, Management and Applied Sciences* 4(2), Pp 219-223.
17. Prajakta D., Seng W., Aniruddha D., and Jack S. (2011). Multi-Agent Based Vehicular Congestion Management, Intelligent Vehicles Symposium (IV) Baden-Baden, (4), Pp 1034-1036.
18. Rajeswaran S. and Rajasekaran S. (2013). A Study of Vehicular Traffic Flow Modeling Based on Modified Cellular Automata. *Journal of Mathematics* 4(5), Pp 32-38.
19. Sinhmar, P. (2012). Intelligent traffic light and density control using IR sensors and microcontroller. *International Journal of Advanced Technology and Engineering Research*, 2(2), Pp 30-35.
20. Syed, Ali Abass, Syed Muhammed Sheraz and Humera Noor (2007). Fuzzy Rule Traffic Signal Control System for Oversaturated Intersections. Department of Computer and Information Systems and Engineering, NED University of Engineering and Technology, Pakistan.
21. Tubaishat, M., Shang, Y., and Shi, H. (2007). Adaptive traffic light control with wireless sensor networks. Paper presented at the Proceedings of IEEE Consumer Communications and Networking Conference.
22. Udoh, S.S. (2016). Adaptive Neuro-Fuzzy Discrete Event System Specification for Monitoring Petroleum Products Pipeline. PhD Dissertation, Department of Computer Science, School of Sciences, Federal University of Technology, Akure, Nigeria. Pp 178-212.
23. Udoh, S. S., Akinyokun O. C., Inyang U. G., Olabode O., Iwasokun G. B. (2017) Discrete Event-Based Hybrid Framework for Petroleum Products Pipeline Activities Classification. *Journal of Artificial Intelligence Research (AIR)* 6(2), Pp 39-50.
24. Udoh, S. S., Umoh U. A., Umoh M. E., (2019). Diagnosis of Prostate Cancer using Soft Computing Paradigms. *Global Journal of Computer Science and Technology (GJCST): Neural and Artificial Intelligence*, 19(2), Pp 19-26.
25. Uthara, E. Prakash, Athira Thankappan, Vishnupriya K. T., and Arun A. Balakrishnan (2018). Density Based Traffic Control System using Image Processing". *International Conference on Emerging Trends and Innovations in Engineering and Technological Research*. Pp 1-4.
26. Zadeh, L.A. (1975). Fuzzy Logic for the Management of Uncertainty.
27. Zhizhou, W., Yiming Z., Guishan T., Jia H. (2019). The research of traffic density extraction method under vehicular adhoc network environment. *Journal of Intelligent and Connected Vehicles* 2(1), pp 25-32.
28. Zhou, B., Cao, J., Zeng, X., and Wu, H. (2010). Adaptive traffic light control in wireless sensor network-based intelligent transportation system. *Paper presented at the Vehicular Technology Conference Fall (VTC 2010-Fall)*.